

# Cuisinart®

Frozen Yogurt-Ice Cream & Sorbet Maker

INSTRUCTION/  
RECIPE BOOKLET

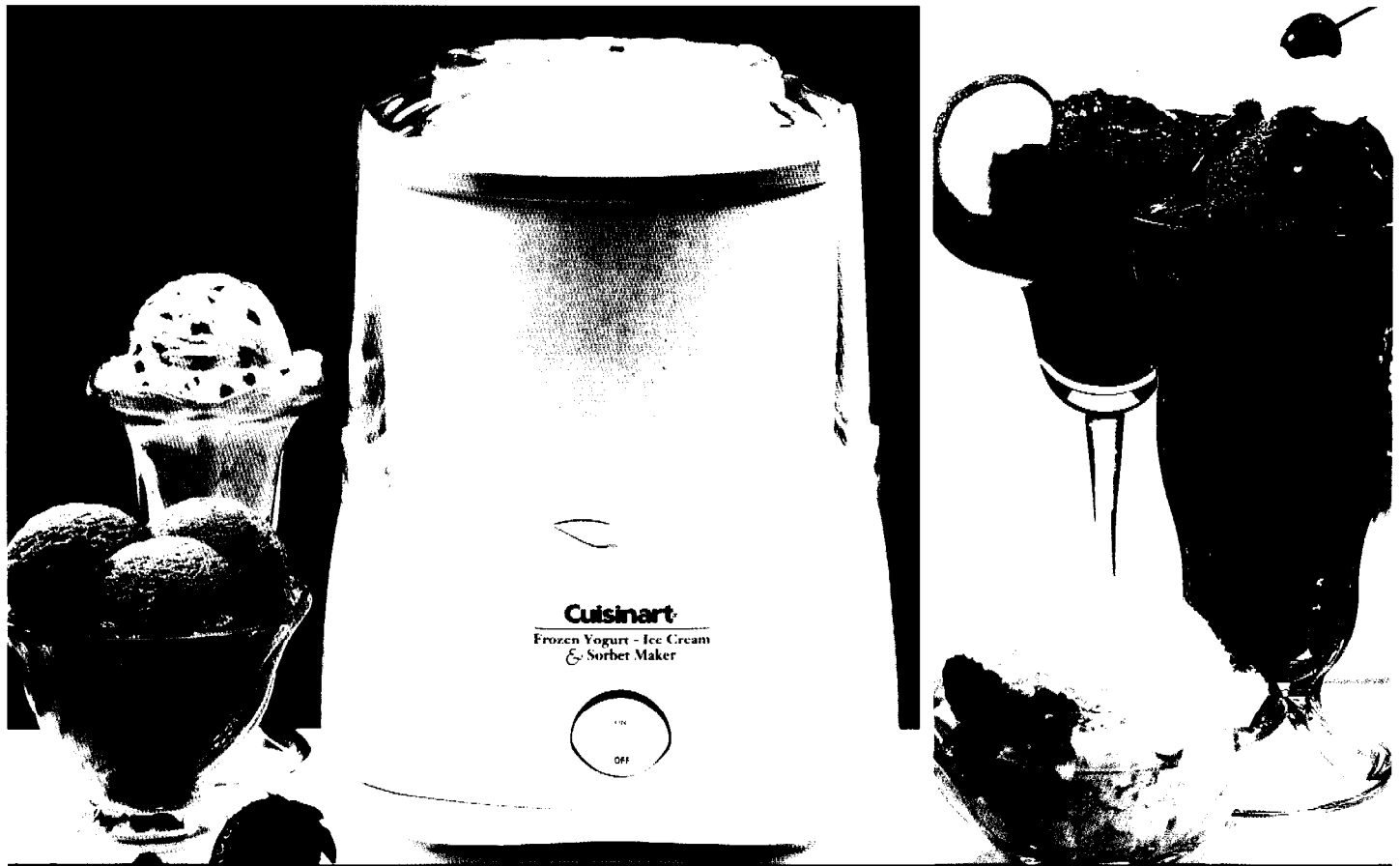

**AUTOMATIC FROZEN YOGURT-ICE CREAM & SORBET MAKER**

**ICE-20**

# IMPORTANT SAFEGUARDS

When using an electrical appliance, basic safety precautions should always be followed to reduce the risk of fire, electric shock, and/or injury to persons including the following:

## 1. READ ALL INSTRUCTIONS BEFORE USING.

2. To protect against risk of electric shock, do not place cord, plug, or base of appliance in water or any other liquid.

3. Close supervision is necessary when any appliance is used by or near children.

4. Unplug from outlet when not in use, before putting on or taking off parts, and before cleaning.

5. Avoid contact with moving parts. Keep hands, hair, clothing, as well as spatulas and other utensils away during operation to reduce the risk of injury to persons, and/or damage to the appliance.

6. Do not operate any appliance with a damaged cord or plug, or after the appliance malfunctions, or is dropped or damaged in any manner. Return the appliance to the nearest Cuisinart Repair Center for examination, repair, electrical or mechanical adjustment.

7. The use of attachments not recommended by Cuisinart may cause fire, electric shock or risk of injuries.

8. Do not use outdoors.

9. Do not let cord hang over edge of table or counter, or touch hot surfaces.

10. Keep hands and utensils out of freezer bowl while in use to reduce the risk of injury to persons or to the appliance itself. **DO NOT USE SHARP OBJECTS OR UTENSILS INSIDE THE FREEZER BOWL!** Sharp objects will scratch and damage the inside of the freezer bowl. A rubber spatula or wooden spoon may be used when

the appliance is in the OFF position.

11. This appliance is for household use. Any servicing other than cleaning and user maintenance should be done only by authorized Cuisinart Repair Personnel.

12. Do not use the freezer bowl on flames, hot plates or stoves. Do not expose to heat source. Do not wash in dishwasher: doing so may cause risk of fire, electric shock or injury.

# SAVE THESE INSTRUCTIONS HOUSEHOLD USE ONLY

## SPECIAL CORD SET INSTRUCTIONS

This appliance has a polarized plug (one blade is wider than the other). To reduce the risk of electric shock, this plug will fit in a polarized outlet only one way. If the plug does not fit fully in the outlet, reverse the plug. If it still does not fit, contact a qualified electrician. Do not attempt to defeat this safety feature.

## CAUTION

This appliance is for household use. Any servicing other than cleaning and user maintenance should be performed by an authorized service representative.

- Do not immerse in water.
- To reduce the risk of fire or electric shock do not disassemble the base. Note: the base does not contain any user-serviceable parts.
- Repairs should be made only by authorized personnel.

- Check voltage to be sure that the voltage indicated on the name plate agrees with your voltage.
- Never clean with scouring powders or hard implements.

## TABLE OF CONTENTS

|  |     |
|--|-----|
| Important Safeguards .....               | p.2 |
| Introduction .....                       | p.2 |
| Features and Benefits .....              | p.3 |
| Before Using for the First Time .....    | p.4 |
| Freezing Time and Bowl Preparation ..... | p.4 |
| Making Frozen Desserts or Drinks .....   | p.4 |
| Adding Ingredients .....                 | p.4 |
| Cleaning and Storage .....               | p.5 |
| Recipes and Recipe Tips .....            | p.5 |
| Warranty .....                           | p.9 |

## INTRODUCTION

*Congratulations!* You've purchased a Cuisinart Automatic Frozen Yogurt-Ice Cream & Sorbet Maker. There's no faster way to make all your favorite frozen desserts. In as little as 20 minutes, you can serve up to 1 ½ quarts of low-fat frozen yogurt or wonderfully rich ice cream. Or, you can make frozen drinks, low-fat sherbets or sorbets. Since you select the ingredients, you know you're treating your family and friends to healthy, naturally delicious frozen delights.

The Cuisinart Automatic Frozen Yogurt-Ice Cream & Sorbet Maker is fully automatic. Just turn on the machine and pour ingredients into the spout. Its double-insulated freezer bowl is engineered to give you even results. Its aerating mixing arm leaves everything creamy and light.

Whether you try the recipes in this booklet or make up your own, you're sure to find your new Cuisinart Automatic Frozen Yogurt-Ice Cream & Sorbet Maker a pleasure to use. Like all Cuisinart appliances, it was designed to bring you years of enjoyment. Backed by 3 3-year limited warranty.

# FEATURES AND BENEFITS

## The Parts:

- 1. Ingredient Spout:**  
Pour recipe ingredients through the spout. Also use to add ingredients, like chips or nuts, without interrupting the freezing cycle.
- 2. Easy-lock lid:**  
Transparent to let you watch the freezing process as it progresses. Lid is designed to easily lock to the base.
- 3. Mixing Arm:**  
Mixes and aerates ingredients in freezer bowl to create the frozen dessert or drink. Creates volume and makes frozen products light and airy.
- 4. Freezer Bowl:**  
Contains cooling liquid between a double insulated wall to create fast and even freezing. Double wall keeps the bowl cool and at an even temperature.
- 5. Base:**  
Contains heavy duty motor strong enough to handle ice cream, frozen yogurt, sherbet, sorbet, and frozen drinks.
- 6. On/Off Switch:**  
Just put switch in the "on" position to begin operation. The Cuisinart® Automatic Frozen Yogurt-Ice Cream & Sorbet Maker does the rest for you.
- 7. Rubber Feet:**  
Non-slip feet keep base stationary during use.
- 8. Cord Storage (Not Shown):**  
Unused cord is easily pushed into the base to keep counters neat and safe.

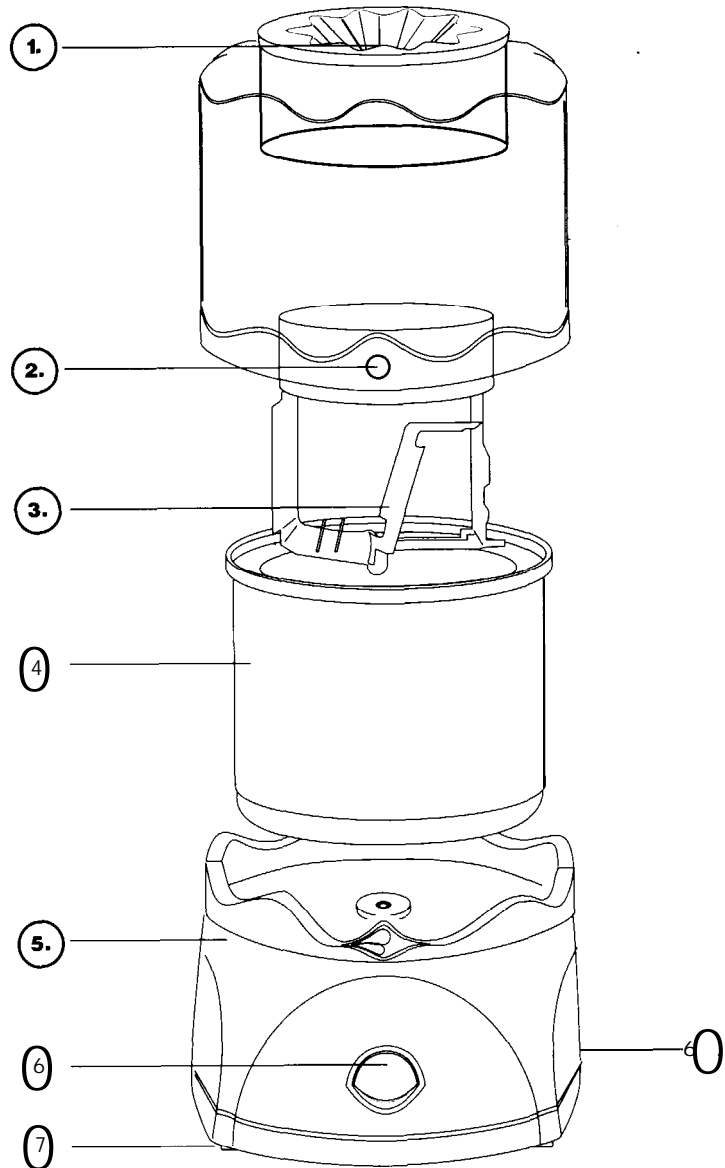

## BEFORE USING FOR THE FIRST TIME

Unpack the Frozen Yogurt–Ice Cream & Sorbet Maker. Remove the foam inserts. Lift up the lid, mixing arm, and freezer bowl. All parts are packed inside each other. Remove the foam insert. Lift out the base. Remove all literature.

DO NOT immerse the motor base in water. Wipe it with a moist cloth. Wash the lid, freezer bowl and mixing arm in warm soapy water to remove any dust or residue from the manufacturing and shipping process. DO NOT clean any of the parts with abrasive cleaners or hard implements.

## FREEZING TIME AND BOWL PREPARATION

The freezer bowl must be completely frozen before you begin your recipe. The length of time needed to reach the frozen state depends on how cold your freezer is. For the most convenient frozen desserts and drinks, leave your freezer bowl in the freezer at all times. You can take it out any time for immediate use.

In general, freezing time is between 6 hours and 22 hours. To determine whether the bowl is completely frozen, shake it. If you do not hear liquid moving, the cooling liquid is frozen.

Before freezing, wash and dry the bowl. Wrap it in a plastic bag to prevent freezer burn. We recommend that you place the freezer bowl in the back of your freezer where it is coldest.

Reminder: Your freezer should be set to 0° F to ensure proper freezing of all foods.

## MAKING FROZEN DESSERTS OR DRINKS!

1. Prepare recipe ingredients from pages that follow or your own recipe. Cuisinart recipes begin on page 5. If you use your own recipe, be sure it yields 1½ quarts or less. For best results, prepare ingredients in a container that is easy to pour from.

2. Remove the freezer bowl from the freezer. (Remove plastic bag, if you have wrapped freezer bowl.) Place bowl on the center of the base.

NOTE: Bowl will begin to defrost quickly once it is removed from freezer. Use it immediately after removing from freezer.

3. Place mixing arm in freezer bowl. Arm does not fit tightly. It just rests in the center of the bowl, with the circle side facing up.

4. Place lid on base. Easy-lock lid mechanism allows lid to rest on base in multiple positions. The raised circle on the lid should line up with the raised area on the base (see diagram).

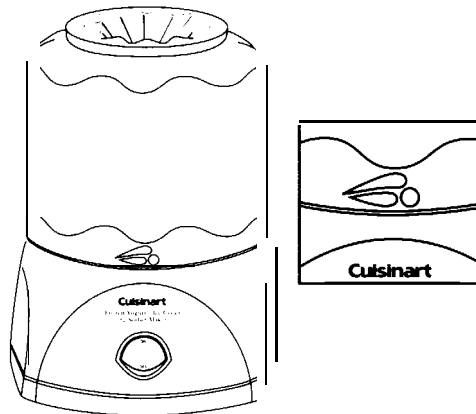

5. Press **On/Off** switch to ON position. Bowl will begin to turn.

6. Immediately pour ingredients through ingredient spout.

7. Frozen Desserts or Drinks will be done in **20-30** minutes.

The time will depend on the recipe and volume of dessert or drink you desire. When the mixture has thickened to your liking, it is done.

If you desire a firmer consistency, transfer the dessert or drink to an airtight container and store in the freezer for two or more hours.

NOTE: Do not store frozen desserts or drinks in the freezer bowl. Desserts and drinks will stick to the side of the freezer bowl and may damage the bowl. Store only in a plastic airtight container.

## ADDING INGREDIENTS

Ingredients such as chips and nuts, should be added about 5 minutes before the recipe is complete. Once the dessert or drink has begun to thicken, add the ingredients through the ingredient spout. Nuts and other ingredients should be no larger than a chocolate chip.

## SAFETY FEATURE

The Cuisinart Automatic Frozen Yogurt–Ice Cream & Sorbet Maker is equipped with a safety feature that automatically stops the unit if the motor overheats. This may occur if the dessert or drink is extremely thick, if the unit has been running for an excessively long period of time, or if added ingredients (nuts, etc.) are in extremely large pieces.

To reset the unit, put the OS/OFF Switch in the OFF position. Let the unit cool off. After a few minutes, you may turn the unit on again and continue making the dessert or drink.

---

## CLEANING AND STORAGE

### Cleaning

Clean the freezer bowl, mixing arm and lid in warm soapy water.

**DO NOT PUT FREEZER BOWL IN THE DISHWASHER. DO NOT CLEAN WITH ABRASIVE CLEANSERS OR IMPLEMENTS.**

Wipe motor base clean with damp cloth.

Dry all parts thoroughly.

### Storage

DO NOT put freezer bowl in freezer if it is wet.

DO NOT store lid, mixing arm, or base in freezer.

You may store the freezer bowl in the freezer for convenient, immediate use. Before freezing, wrap the bowl in a plastic bag to prevent freezer burn.

Do not store frozen desserts or drinks in the freezer bowl in the freezer for more than 30 minutes at a time.

Transfer frozen desserts or drinks to an airtight container for longer storage in the freezer.

## RECIPE TIPS

The recipes that follow offer you a variety of options for delicious frozen drinks and desserts. You may create or use recipes of your own, as long as they yield no more than 1½ quarts.

### Recipe tips:

- Frozen desserts from the Cuisinart Automatic Frozen Yogurt-Ice Cream & Sorbet Maker use pure, fresh ingredients. Because of this, the desserts and drinks do not have the same characteristics of commercially prepared frozen desserts and drinks. Most store-bought versions use gums and preservatives to make them firmer. If you desire a firmer consistency transfer the dessert or drink to an airtight container and store in the freezer until desired consistency is reached, usually two or more hours.

- Some recipes use pre-cooked ingredients. For best results, the mixture should be chilled overnight before using. Or, chill the recipe over an ice bath, until it is completely cooled, before using.
- To make an ice bath, fill a large container with ice and water. Place saucepan or other container into the ice bath. Cool (pre-cooked) ingredients completely.
- Prior to freezing, most recipes must be stored in the refrigerator for up to 3 days.
- You may substitute lower fat creams (e.g. half and half) and milks (2%, 1%) for heavy cream and whole milk used in many recipes. However, keep in mind that the higher the fat content, the richer and creamier the result. Using lower fat substitutes may change the taste, consistency and texture of the dessert. When substituting, be sure to use the same volume of the substitute as you would have used of the original item. For example, if the recipe calls for two cups of cream, use a total of two cups of the substitute (such as 1 cup cream, 1 cup whole milk).
- You may substitute artificial sweeteners for sugar. If the recipe is to be pre-cooked, add the sweetener *after* the heating process is complete and ingredients have cooked. Stir the mixture thoroughly to dissolve the sweetener.
- In recipes that use alcohol, add the alcohol during the last two minutes of the freezing process. Otherwise, the alcohol may impede the freezing process.
- When making sorbet, be sure to test the ripeness and sweetness of the fruit before you use it. The freezing process reduces the sweetness of the fruit so that it tastes less sweet than the recipe mixture. If the fruit tastes tart, add sugar to the recipe. If the fruit is very ripe or sweet, reduce the amount of sugar noted in the recipe.
- The Cuisinart recipes listed below will yield up to 1½ quarts of dessert or drink. When pouring your recipe in through the ingredient spout,

DO NOT fill the freezer bowl more than 1/4" from the top of the freezer bowl. The ingredients will increase in volume during the freezing process.

- When making more than one recipe at a time, be sure the freezer bowl is completely frozen before each use.
- Make sure mixing arm and lid are in place before returning machine on.

## QUICK & SIMPLE RECIPES

The following recipes are easy to prepare, contain no eggs and require no cooking.

### SIMPLE VANILLA ICE CREAM

Easier than ever to make. Simply combine ingredients and freeze.

Makes: Ten 1/2-cup servings

- 2 cups heavy cream, chilled
- 1 cup whole milk, chilled
- ¾ cup sugar
- 1 teaspoon vanilla extract

Place ingredients in a medium mixing bowl and combine until well blended. Pour into freezer bowl, turn the machine ON and let mix until mixture thickens, about **20-25** minutes. If desired, transfer ice cream to an airtight container and place in freezer until firm, about 2 hours.

Nutritional information per serving:

Calories 242 (67% from fat) carbo. 18g. pro. 2g. fat 18g. sat. fat 11g. chol. 69mg. sod. 30mg.

---

### Variations:

*Creamy Coconut: Omit vanilla extract and add 1/2 teaspoon coconut extract. Add 1/4 cup shredded coconut during the last 5 - 10 minutes of freezing.*

*Mint Chip: Omit vanilla extract and add 1/2 teaspoon mint extract. Add 1/2 cup mini chocolate chips during the last 5 - 10 minutes of freezing.*

---

**Fruit Ice Cream:** Add 1/2 cup coarsely chopped fruit (seeds and pits removed) during the last 5-10 minutes of freezing.

### SIMPLE **CHOCOLATE-** ALMOND ICE CREAM

Use a good quality chocolate syrup for best flavor.

Makes: Ten 1/2-cup servings

- 2 cups heavy cream, chilled
- 1 cup whole milk, chilled
- 1/2 cup chocolate syrup
- 2 tablespoons sugar
- 1/2 teaspoon almond extract

Place ingredients in a medium mixing bowl and combine until well blended. Pour into freezer bowl; turn the machine OS and let mix until mixture thickens, about 20-25 minutes. If desired, transfer ice cream to an airtight container and place in freezer until firm, about 2 hours.

Nutritional information per serving:  
Calories 104 (0% from fat), carbo. 13g, pro. 0g,  
sat. fat 0g, chol. 0mg, sod. 8mg.

### PISTACHIO ICE CREAM

Ground pistachio nuts add rich flavor to this delicious dessert.

Makes: Twelve 1/2-cup servings

- 2 cups heavy cream, chilled
- 1 cup whole milk, chilled
- 1 cup coarsely chopped pistachio nuts
- 1 cup sugar
- 1/2 teaspoon vanilla extract
- 1 drop green food coloring (optional)

Place ingredients in a medium mixing bowl and combine until well blended. Pour into freezer bowl, turn the machine ON and let mix until mixture thickens, about 20-25 minutes.

If desired, transfer ice cream to an airtight container and place in freezer until firm, about 2 hours.

Nutritional information per serving:  
Calories 253 (75% from fat), carbo. 21g, pro. 4g,  
fat 21g, sat. fat 10g, chol. 57mg, cod. 26mg.

### EASY FROZEN LEMONADE

Thick, slushy and refreshing. It tastes like it is hard to make.

Makes: Four 1-cup servings

- 4 cups lemonade, chilled

Pour into freezer bowl, turn the machine ON and let mix until mixture is thick and slushy; about 20 minutes. Pour into glasses and serve immediately.

Nutritional information per serving:  
Calories 104 (0% from fat), carbo. 26g, pro. 0g,  
fat 0g, sat. fat 0g, chol. 0mg, sod. 8mg.

### CHOCOLATE **FUDGICLE** ICE CREAM

Kids love it! It's easy to make and fun to eat. It even stays soft in the freezer.

Makes: Eight 1/2-cup servings

- 1 cups whole milk
- 1 4-ounce package chocolate instant pudding

Place ingredients in a medium mixing bowl and combine until well blended. Pour into freezer bowl, turn the machine OS and let mix until mixture thickens, about 15-20 minutes. Serve immediately, or if desired, transfer to an airtight container and store in the freezer.

Nutritional information per serving:  
Calories 90 (20% from fat), carbo. 16g, pro. 2g,  
fat 2g, sat. fat 1g, chol. 8mg, sod. 87mg.

### FROZEN BANANA CREAM PUDDING

Children love to help make this creamy frozen dessert... and they love to eat it too!

Makes: Eight 1/2-cup servings

- 3 cups whole milk
- 1 1-ounce package banana cream instant pudding

Place ingredients in a medium mixing bowl and combine until well blended. Pour into freezer bowl, turn the machine OS and let mix until mixture thickens, about 15-20 minutes. Serve immediately, or if desired, transfer to an airtight container and store in the freezer.

Nutritional information per serving:  
Calories 107 (25% from fat), carbo. 17g, pro. 3g,  
fat 3g, sat. fat 2g, chol. 12mg, sod. 102mg.

### SLUSHY **KOOL-AID**

A refreshing treat for busy kids.

Makes: Eight 1/2-cup servings

- 4 cups Kool-Aid<sup>®</sup>, chilled

Pour into freezer bowl, turn the machine OS and let mix until mixture thickens, about 15-20 minutes. Serve immediately, or if desired, transfer to an airtight container and store in the freezer.

Nutritional information per serving:  
Calories 48 (0% from fat), carbo. 12g, pro. 0g,  
fat 0g, sat. fat 0g, chol. 0mg, sod. 7mg.

---

## GOURMET RECIPES

### LOW-FAT PEACH FROZEN YOGURT

‘This dessert has such a creamy consistency, you’ll never believe it is low-fat.

Makes: Eight 1/2-cup servings

- 1 can (14 ounces) peaches packed in juice
- 2 cups low-fat vanilla yogurt
- 1/4 cup sugar

Drain peaches, reserving 1/2 cup of juice. Purée peaches in a Mender. Add yogurt, reserved juice and sugar; blend until combined. Pour into freezer bowl, turn the machine ON and let mix until thickened, about 25 - 30 minutes. If desired, place frozen yogurt in an airtight container and place in freezer until firm, about 2 hours.

Nutritional information per serving:  
Calories 113 (8% from fat), sat. fat 0g, total fat 1g, carbo. 23g, prot. 3g, chol. 2mg, sod. 35mg.

### VERY BERRY FROZEN YOGURT

Frozen berries make this delicious dessert possible year round. Of course fresh berries may be used in season.

Makes: Eight 1/2-cup servings

- 2 cups low-fat vanilla yogurt
- 1 12-ounce bag frozen mixed berries, puréed and strained, or 2 cups puréed and strained fresh berries
- 1/2 cup whole milk
- 1/4 cup sugar

Combine all ingredients in a medium mixing bowl using a hand mixer on medium speed. Pour into freezer bowl, turn the machine ON and let mix until thickened, about 25 - 30 minutes. If desired, transfer frozen yogurt to an airtight container and place in freezer until firm, about 2 hours.

Nutritional information per serving:  
Calories 110 (8% from fat), sat. fat 1g, total fat 1g, carbo. 21g, prot. 3g, chol. 4mg, sod. 41mg.

### CHOCOLATE FROZEN YOGURT

Lower in fat than traditional ice cream, the chocolate flavor is rich and satisfying.

Makes: Eight 1/2-cup servings

- 1 cup whole milk
- 6 ounces semisweet chocolate chips
- 2 cups low-fat vanilla yogurt
- 1/4 cup sugar

Combine milk and chocolate in a Mender or food processor until well blended and smooth, about 15 seconds. Add yogurt and sugar; process until smooth, about 15 seconds. Pour into freezer bowl and let mix until thickened, about 25-30 minutes. If desired, transfer frozen yogurt to an airtight container and place in freezer until firm, about 2 hours.

---

#### Variation:

*Substitute 6oz. of hazelnut chocolate for semisweet chocolate chips.*

Nutritional information per serving:  
Calories 223 (37% from fat), sat. fat 5g, total fat 9g, carbo. 31g, prot. 4g, chol. 7mg, sod. 49mg.

### PREMIUM VANILLA ICE CREAM

Vanilla bean adds to the rich flavor of this premium ice cream. It’s delicious alone or as an accompaniment to warm pies and desserts.

Makes: Ten 1/2-cup servings

- 2 cups heavy cream
- 2 cups whole milk
- 1 2-inch piece vanilla bean, split lengthwise
- 2 egg yolks
- 1/2 cup sugar
- 2 tablespoons vanilla extract

Combine cream and milk in a medium saucepan over medium heat. Add vanilla bean and heat until mixture almost boils, about 5 - 8 minutes. Reduce heat to low.

Meanwhile beat yolks, sugar and vanilla extract in a small bowl until light yellow and smooth, about 1-2 minutes. Add 4 tablespoons hot cream/milk mixture and stir until combined. Gradually add egg yolk mixture to a-arm cream mixture, stirring continuously to prevent the eggs from curdling. Cook over low heat until slightly thickened and mixture coats the back of a spoon, about 3-4 minutes. Cool completely\*. When cool, scrape seeds from vanilla bean and add to ice cream mixture. Discard bean shell. Stir until well combined. Pour into freezer bowl, turn the machine ON and let mix until mixture thickens, about 20-25 minutes. If desired, transfer ice cream to an airtight container and place in freezer until firm, about 2 hours.

\*Place mixture in a covered container and store in the refrigerator overnight. Or chill over an ice bath for about 30 minutes if you wish to make ice cream right away.

---

#### Variations:

*Add 1/2 cup of butterscotch or chocolate chips during the last 5 minutes of mixing.*

*Add 1/2 cup of crushed chocolate sandwich cookies during the last 5 minutes of mixing.*

*Add 1/2 cup of crushed peppermint candies during the last 5 minutes of mixing.*

Nutritional information per serving:  
Calories 248 (2% from fat), sat. fat 12g, total fat 20g, carbo. 14g, prot. 3g, chol. 113mg, sod. 45mg.

## QUICK VANILLA ICE CREAM

This simple recipe is easy to make and children enjoy helping! We use egg substitute to reduce the risk of using uncooked eggs.

Makes: Ten X-cup servings

2/3 cup sugar  
1/2 cup egg substitute  
2 cups heavy cream  
1-3/4 cups whole milk  
1 tablespoon vanilla extract

Place sugar and egg substitute in a large mixing bowl and beat on medium speed with an electric hand mixer until light and fluffy, about 2-3 minutes. Add cream, milk and vanilla. Mix on medium speed until combined, about 1-2 minutes. Pour into freezer bowl, turn the machine ON and let mix until mixture thickens, about 20-25 minutes. If desired, transfer ice cream to an airtight container and place in freezer until firm, about 2 hours.

### Variations:

*Add 1/2 cup mini chocolate chips or mini M&M<sup>®</sup> candies during last 5 minutes of mixing.*

*Add 1/4 cup mini chocolate chips and 1/4 cup coarsely chopped walnuts during last 5 minutes of mixing.*

Nutritional information per serving:  
Calories 247 (69% from fat), sat. fat 12g, total fat 19g, carbo. 16g, prot. 3g, chol. 69mg, sod. 52mg.

## STRAWBERRY ICE CREAM

A creamy delicious treat. Frozen strawberries may be substituted when fresh are not available.

Makes: Ten 1/2-cup servings

1-1/2 cups strawberries, washed and hulled\*  
1-1/2 cups heavy cream  
1-1/2 cups whole milk  
1 egg yolks  
1/2 cup sugar  
2 tablespoons vanilla extract

Finely chop strawberries in a food processor; reserve. (This will yield 1 cup of chopped strawberries.)

Combine cream and milk in a medium saucepan over medium heat and cook until mixture almost boils, about 5-8 minutes. Reduce heat to low.

Meanwhile beat yolks, sugar and vanilla extract in a small bowl until light yellow and smooth, about 1-2 minutes. Add 4 tablespoons hot cream/milk mixture and stir until combined. Gradually add egg yolk mixture to warm cream mixture, stirring continuously to prevent the eggs from curdling. Cook over low heat until slightly thickened and mixture coats the back of a spoon, about 3-4 minutes. Cool completely\*\*. When cool add reserved strawberries and stir until well combined. Pour into freezer bowl, turn the machine ON and let mix until mixture thickens, about 20-25 minutes. If desired, transfer ice cream to an airtight container and place in freezer until firm, about 2 hours.

\* For frozen strawberries: Use 1-1/2 cups frozen whole strawberries (no sugar added). Partially defrost. Chop in a food processor when they are soft enough to be pierced with a sharp knife. (This will yield 1 cup of chopped strawberries.)

\*\* Place mixture in a covered container and store in the refrigerator overnight. Or chill over an ice bath for 30 minutes if you wish to make ice cream right away.

Nutritional information per serving:  
Calories 216 (67% from fat), sat. fat 9g, total fat 16g, carbo. 15g, prot. 3g, chol. 95mg, sod. 33mg.

## RICH CHOCOLATE ICE CREAM

Creamy!; delicious and smooth, a favorite of choc-o-holics everywhere!

Makes: Eight 1/2-cup servings

5 ounces semi-sweet chocolate, finely chopped  
2 cups heavy cream  
2 cups whole milk  
2 egg yolks  
1/2 cup sugar  
1 tablespoon pure vanilla extract

Break chocolate pieces into 1/2-inch pieces and finely chop in a food processor.

Combine cream, milk and chocolate in a medium saucepan over medium heat and cook until mixture almost boils and chocolate is melted, about 5-8 minutes. Reduce heat to low.

Meanwhile beat yolks, sugar and vanilla extract in a small bowl until light yellow and smooth, about 1-2 minutes. Add 4 tablespoons of warm cream/chocolate mixture and stir until combined. Gradually add egg yolk mixture to warm cream/chocolate mixture, stirring continuously to prevent the eggs from curdling. Cook over low heat until slightly thickened and mixture coats the back of a spoon, about 3-4 minutes. Cool completely\*. Stir gently and pour into freezer bowl. Turn the machine ON and let mix until mixture thickens, about 25-30 minutes. If desired, transfer ice cream to an airtight container and place in freezer until firm, about 2 hours.

\*Place mixture in a covered container and store in the refrigerator overnight. Or chill over an ice bath for 30 minutes if you wish to make ice cream right away.

### Variation:

*Add 1/2 cup of white chocolate chips during the last 5 minutes of mixing.*

Nutritional information per serving:  
Calories 313 (72% from fat), sat. fat 15g, total fat 25g, carbo. 18g, prot. 4g, chol. 141mg, sod. 54mg.



## FRESH LEMON SORBET

Bits of grated lemon zest add a burst of flavor to this refreshing sorbet.

Makes: Eight 1/2-cup servings

- 2 cups sugar
- 2 cup5 water
- 1-W cups fresh lemon juice  
(juice of about 6 lemons)
- 1 tablespoon grated lemon zest\*

Combine sugar and water in a medium saucepan and bring to a boil over medium-high heat. Reduce heat to low and simmer until sugar dissolves, about 3 -4 minutes. Cool completely\*\*. When cool, add lemon juice and zest; stir to combine. Pour into freezer bowl, turn the machine OS and mix until mixture thickens. about 25 -30 minutes. If desired, transfer sorbet to an airtight container and place in freezer until firm, about 2 hours.

\* Zest is the colored part of the citrus rind. Do not use the white pith. For best results, remove zest from the lemon with a vegetable peeler.

\*\* Place mixture in a covered container and store in the refrigerator overnight. Or chill over an ice bath for 30 minutes if you wish to make sorbet right away.

Nutritional information per serving:  
Calories 216 (0% from fat). sat. fat 0g. total fat 0g.  
carbo. 54g. prot. 0g. chol. 0mg. sod. 1mg.

## RASPBERRY SORBET

A COOL and fruity dessert, this sorbet makes a simple, yet elegant frozen treat.

Makes: Eight 1/2-cup servings

- 2 cups sugar
- 2 cups water
- 12 ounce bag frozen raspberries,  
puréed and strained (about 1 cup)
- 4 teaspoon5 lemon juice

Combine sugar and water in a medium saucepan and bring to a boil over medium-high heat.

Reduce heat to low and simmer until sugar dissolves, about 3 -4 minutes. Cool completely\*. When cool, add raspberries and lemon juice; stir to combine. Pour into freezer bowl, turn the machine OS and let mix until mixture thickens, about 25-30 minutes. If desired, transfer sorbet to an airtight container and place in freezer until firm, about 2 hours.

\* Place mixture in 3 covered container and store in the refrigerator overnight. Or chill over an ice bath for 30 minutes if you wish to make sorbet right away.

Nutritional information per serving:  
Calories 244 (0% from fat). sat. fat 0g. total fat 0g.  
carbo. 61g. prot. 0g. chol. 0mg. sod. 1mg.

## PINK GRAPEFRUIT SORBET

Tart but sweet, fresh grapefruit juice adds pizzazz to this delicate sorbet.

Makes: Eight 1/2-cup servings

- 2 cups sugar
- 2 cups water
- 1-1/2 cups fresh grapefruit juice
- 1 tablespoon finely grated grapefruit zest\*

Combine sugar and water in a medium saucepan and bring to a boil over medium-high heat. Reduce heat to low and simmer until sugar dissolves, about 3-4 minutes. Cool completely\*\*. When cool, add grapefruit juice and zest; stir to combine. Pour into freezer bowl, turn the machine OS and let mix until mixture becomes slush!. about 25-30 minutes. If desired, transfer sorbet to an airtight container and place in freezer until firm, about 2 hours.

\* Zest is the colored part of the citrus rind. Do not use the white pith. For best results, remove zest with a vegetable peeler.

\*\* Place mixture in a covered container and store in the refrigerator overnight. Or chill over an ice bath for 30 minutes if you wish to make sorbet right away.

Nutritional information per serving:  
Calories 276 (0% from fat). sat. fat 0g. total fat 0g.  
carbo. 68g. prot. 1g. chol. 0mg. sod. 2mg.

## LIME SHERBET

COOL and refreshing, lime sherbet has been a favorite for years!

Makes: Eight 1/2-cup serving

- 3 cups whole milk
- 1 cup frozen limeade concentrate, thawed
- 3 tablespoons sugar
- 7 drops green food coloring, optional

Combine ingredients in a food processor or blender. Pour into freezer bowl turn the machine OS and let mix until mixture thickens. about 25-30 minutes. If desired, transfer sherbet to an airtight container and place in freezer until firm, about 2 hours.

Nutritional information per serving:  
Calories 131 (21% from fat). sat. fat 2g. total fat 3g.  
carbo. 23g. prot. 3g. chol. 12mg. sod. 45mg.

---

## ORANGE SHERBET

A favorite children will enjoy. Serve with vanilla ice cream for a creamsicle flavor.

Makes: Eight 1/2-cup servings

2-1/2 cups whole milk

3/4 cup frozen orange juice concentrate, thawed

2 tablespoons sugar

Combine all ingredients in a blender or food processor; process to combine, about 15 seconds. Pour into freezer bowl, turn the machine ON and let mix until mixture thickens, about 20 - 25 minutes. If desired, transfer sherbet to an airtight container and place in freezer until firm, about 2 hours.

Nutritional information per serving:

Calories 107 (25% from fat). sat. fat 2g.

total fat 3g. carbo. 17g. prot. 3g. chol. 10mg.

sod. 38mg.

## THICK AND FROSTY PIÑA COLADAS

A frozen beverage reminiscent of the islands. Garnish with shredded coconut if desired.

Makes: Twelve 1/2-cup servings

3 cups whole milk

1 can (10-ounces) frozen piña colada concentrate, thawed

1 teaspoon rum extract

Combine milk, piña colada concentrate and rum extract in a blender or food processor. Process to combine, about 15 seconds. Pour into freezer bowl, turn the machine ON and let mix until mixture becomes slush; about 20 - 25 minutes. Serve immediately for frozen drinks. To serve as a frozen dessert, transfer to an airtight container and place in freezer until firm, about 2 hours.

Nutritional information per serving:

Calories 115 (76% from fat). sat. fat 8g. total fat

10g. carbo. 4g. prot. 3g. chol. 8mg. sod. 34mg.

## FROZEN STRAWBERRY DAIQUIRI

Impress your friends with these smooth and delicious drinks. Or freeze them for a uniquely flavored dessert.

Makes: Ten 1/2-cup servings

1 cup strawberries, washed and hulled or frozen strawberries with no sugar added

2-1/2 cups water

2/3 cup sugar

1/2 cup lime juice

1/2 cup light rum

Place strawberries in a blender or food processor; process to purée. Add remaining ingredients and process until smooth. Pour into freezer bowl, turn the machine ON and mix until slushy, about 20 - 25 minutes. Serve immediately as a frozen beverage. To serve as a frozen dessert, transfer to an airtight container and place in freezer until firm, about 2 hours.

Nutritional information per serving:

Calories 83 (0% from fat). sat. fat 0g. total fat 0g.

carbo. 14g. prot. 0g. chol. 0mg. sod. 1mg.

alcohol 4g.

---

# WARRANTY

## THREE-YEAR LIMITED WARRANTY

This warranty supersedes all previous warranties on the Cuisinart Automatic Frozen Yogurt-Ice Cream & Sorbet Maker.

This warranty is available to consumers only. You are a consumer if you own a Cuisinart Automatic Frozen Yogurt-Ice Cream & Sorbet Maker that was purchased at retail for personal, family or household use. Except as otherwise required under applicable state law, this warranty is not available to retailers or other commercial purchasers or owners.

We warrant that your Cuisinart Automatic Frozen Yogurt-Ice Cream & Sorbet Maker will be free of defects in material or workmanship under normal home use for three years from the date of original purchase.

We suggest that you complete and return the enclosed warranty registration card promptly to facilitate verification of the date of original purchase. However, return of the warranty registration is not a condition of these warranties.

If your Automatic Frozen Yogurt-Ice Cream & Sorbet Maker should prove to be defective within the warranty period, we will repair it (or if we think it necessary, replace it) without charge to you. To obtain warranty service, please call our Consumer Service Center toll-free at 1-800-726-0190 or write to:

Cuisinart  
150 Milford Road  
East Windsor, NJ 08520

To facilitate the speed and accuracy of our return, please also enclose \$10.00 for shipping and handling of the product (California residents need only supply proof of purchase and should

call 1-800-726-0190 for shipping instructions). Please also be sure to include a return address, description of the product defect, product serial number, and any other information pertinent to the product's return. Please pay by check or money order.

Your Cuisinart Automatic Frozen Yogurt-Ice Cream & Sorbet Maker has been manufactured to strict specifications and has been designed for use with the Cuisinart Automatic Frozen Yogurt-Ice Cream & Sorbet Maker accessories and replacement parts. These warranties expressly exclude any defects or damages caused by accessories, replacement parts or other repair service other than those that have been authorized by Cuisinart.

These warranties do not cover any damage caused by accident, misuse, shipment or other than ordinary household use.

These warranties exclude all incidental or consequential damages. Some states do not allow the exclusion of or limitation of incidental or consequential damages, so the foregoing limitation may not apply to you.

---

©1997 Cuisinart  
M&M<sup>®</sup> is a registered trademark of Mars,  
Incorporated  
Kool-Aid<sup>®</sup> Brand is a registered  
trademark of Kraft Foods, Inc.  
Cuisinart<sup>®</sup> is a registered trademark of  
Cuisinart  
150 Milford Road  
East Windsor, NJ 08520  
Printed in China  
IB-2750B  
97CU9158